

Component General, Inc.

P/N: CHT - 200-2 NF

Coaxial Terminations



Electrical Specifications

Power:

200 W on Adequate
Heat Sink.

Frequency Range:

DC - 1.0 GHz

VSWR (Max.):

1.08:1

Impedance:

50 Ω

Mechanical Specifications

Cover:

Aluminum, Gold iredited .

Connector:

Brass, Nickel plated.

Housing:

Copper, Bare .

Insulator:

PTFE, Virgin grade.

Part Dimensions

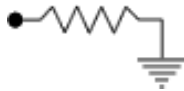
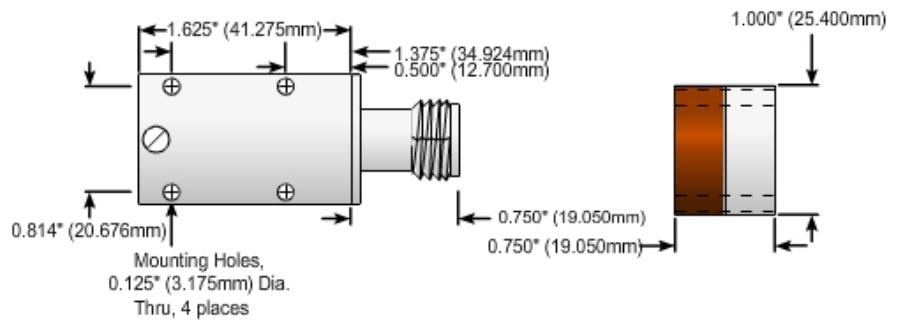

The CHT Series high power coaxial terminations are conduction cooled loads. They are designed to be mounted on a heat sink ground plane or a chill plate. The power ratings require that the base plate of the CHT-15-2 does not exceed 100°C or 85°C for all other sizes.



2445 Success Drive Odessa, FL 33556
727-376-6655 or 800-246-4084