

Component General, Inc.

P/N: CHT- 250 SM

Coaxial Terminations

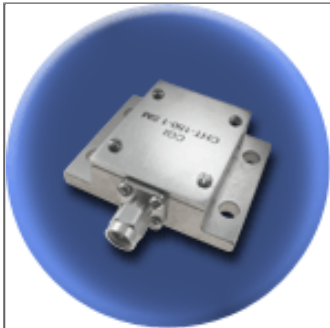

Electrical Specifications

	Frequency Range:	VSWR (Max.):
Power: 250 W.	DC - 200 MHz	1.15:1
	200 - 400 MHz	1.25:1
	400 - 800 MHz	1.30:1
Impedance: 50 Ω		

Mechanical Specifications

Connector:

Stainless Steel, Passivated.

Contact:

Beryllium Copper, Silver plated.

Housing:

Copper, Nickel plated.

Insulator:

PTFE, Virgin grade.

Part Dimensions

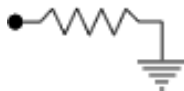
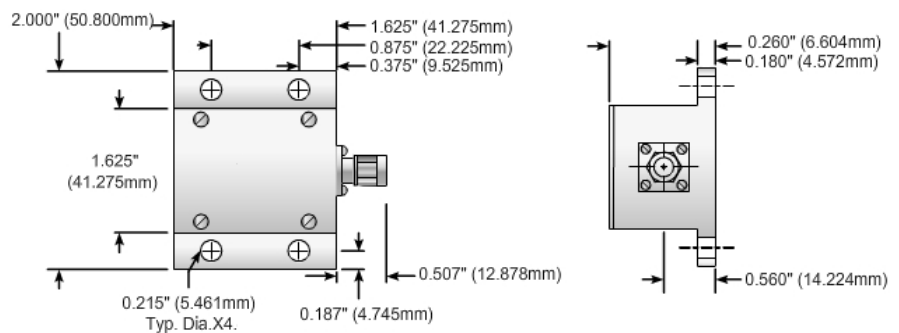

The CHT Series high power coaxial terminations are conduction cooled loads. They are designed to be mounted on a heat sink ground plane or a chill plate. The power ratings require that the base plate of the CHT-15-2 does not exceed 100°C or 85°C for all other sizes.



2445 Success Drive Odessa, FL 33556
727-376-6655 or 800-246-4084